

# PLUNGIE DOWNUNDER ROLLER

## INSTALLATION GUIDE

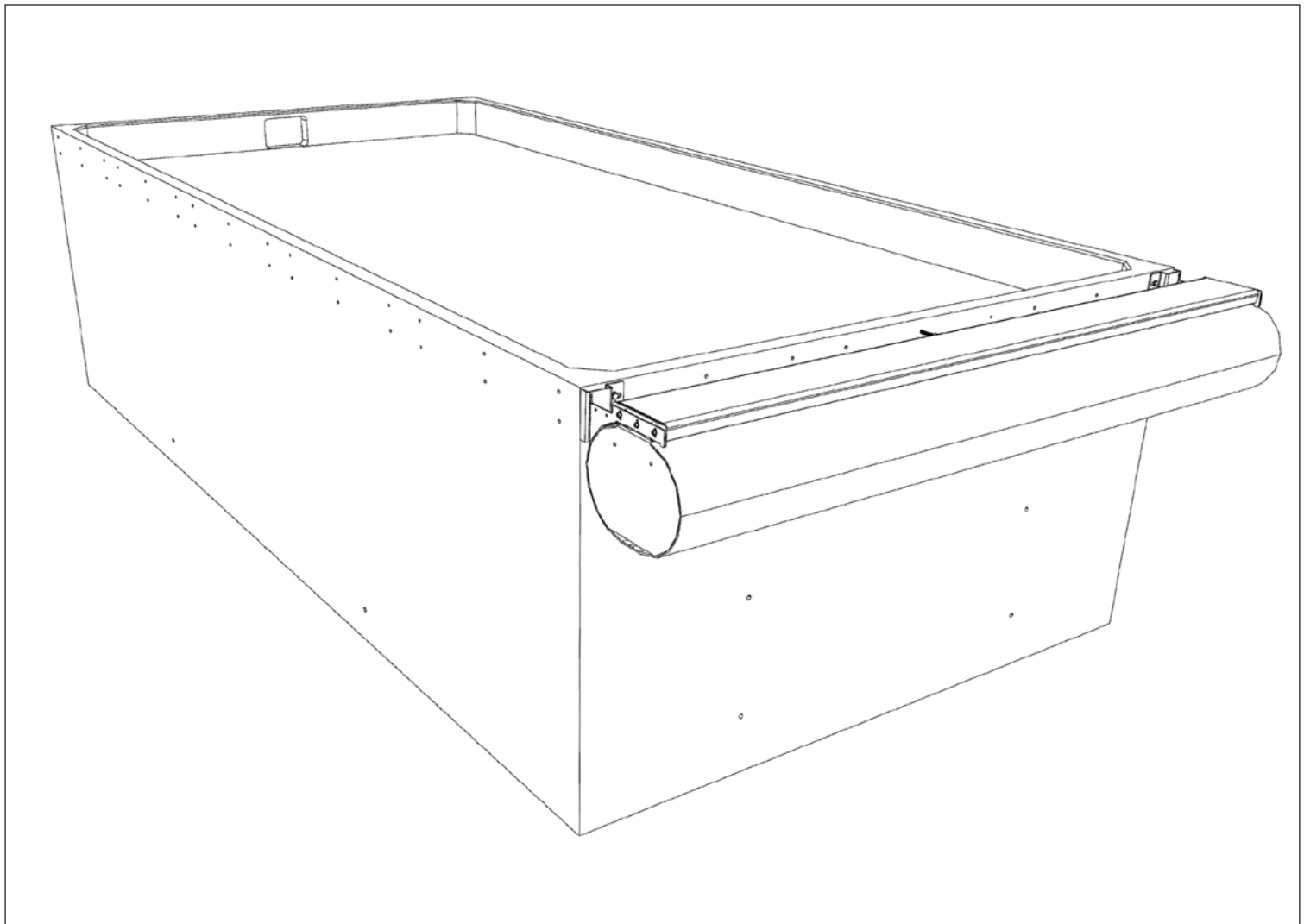

## Tools Required



LANDSCAPING  
EQUIPMENT  
*Depending on install*



TAPE MEASURE



SPIRIT LEVEL



5 & 6MM ALLEN KEY



19MM / ADJUSTABLE  
SPANNER



SUITABLE PPE  
*PPE Should be worn while  
assembling/installing product*

## Supplied Parts



1 X DOWNUNDER UNIT

## Upgrade kit - Installation Bracket



2 X WALL PLATES



2 X END BRACKETS



6 X M8 10MM CAP  
SCREWS & WASHERS



CENTRE PLATE



6 X M8 10MM CAP  
SCREWS & WASHERS



M12 40MM  
(COUPLER-NUT)



M6 CSK SCREW



M12 110 ALL THREAD

### IMPORTANT

The Installation bracket is for installation assistance only and must be backfilled within 48 hours of installation.

## Equipotential Bonding

In compliance with AS/NZS 3000:2018, if the Downunder is installed within a distance of 1,250mm ('arm's reach') from the pool's edge, it is essential to engage a licensed electrician to perform equipotential bonding for the unit. It is also advisable to verify and adhere to any relevant state legislation before initiating any work in this regard.

# Downunder In-Ground

## INSTALLATION WITH NO MOUNTING BRACKET

### Digging the Pit

**Cavity:** The cavity is to be a minimum of 50mm wider than the Downunder casing on each side, at a depth of 600mm. **A**

**Downunder size:** W500mm x H445mm x L Calculated. **B**

### Ensuring Proper Drainage

- Install a layer of screening at the pit's bottom, with a minimum depth of 150mm. Use screenings of at least 12mm size without fines for optimal drainage. **C**
- It is recommended that a drainage pipe is run beneath the unit to efficiently redirect water away. In cases of poor drainage or high water table environments this is essential. **D**

**Note:** It is the Installer's responsibility to identify and provide adequate pit drainage.

### Unit installation method

For efficiency and accuracy, Sunbather recommends using the Mounting Installation Kit. This secures the Downunder in place at the required height and position for installation. Skip to the **next page** for mounting bracket installation instructions.

### Installing the Unit and Backfilling without a bracket

- Remove protective cover from the lid so you can check level of unit.
- Place the unit in the pit, resting it on the screenings.
- Adjust the height so the top of the lid/end plate is level with the top of the pool pavers(surface layer). **E**
- Replace protective cover to ensure no damage to the lid.
- Backfill around the unit approximately half the height of the unit. Do not cut any internal braces or protective coverings before installation. **F**

### Concreting and Paving/surface layer

- Ensure concrete ties are set to be fully encased in concrete, ideally linked to reinforcing bars for stability. **G**
- Cover the backfill with concrete allowing space for the paving(surface layer). Finish paving ensuring its finished height is level with the end plate (datum line).
- Keep the protective cover on until all paving work is finished and cured. Only then, remove the cover.
- The builder must take care to avoid damaging the hinged lid during the installation process as concrete will burn anodising.

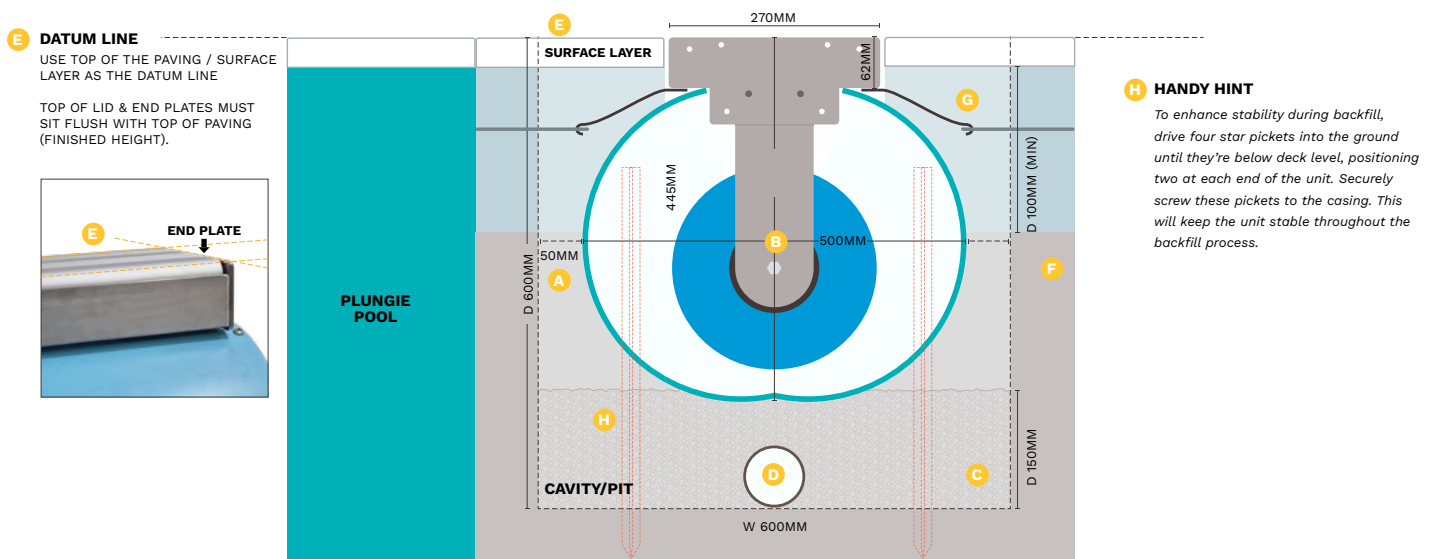

# Mounting Bracket Installation

1. Work out the left and right mounting brackets. The space between the edge and the bolt hole is widest at the top. Bolt holes are on the inner side. **A**
2. Align and mount each mounting bracket with M12 bolts and washers. **B**
3. Install the side arm brackets on both sides of the Sunbather, ensuring they are parallel to the pool surface. **C**
4. Attach the centre plate onto the Downunder using 6M CSK screws. **D**

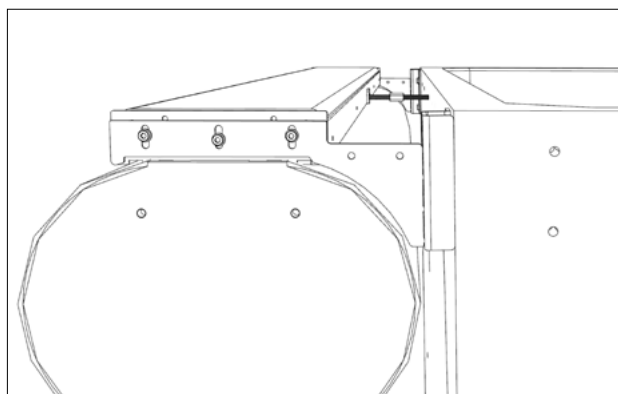
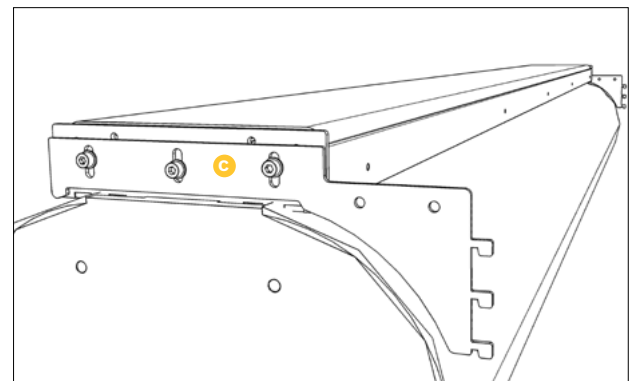
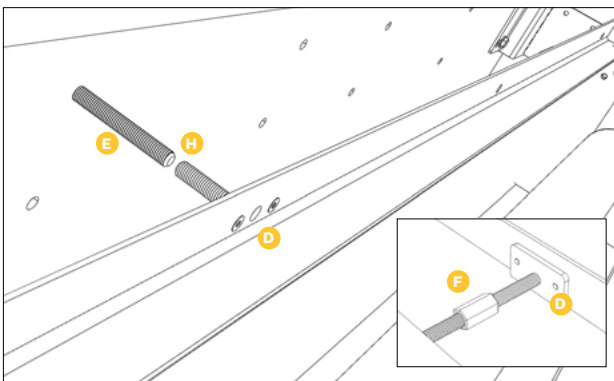
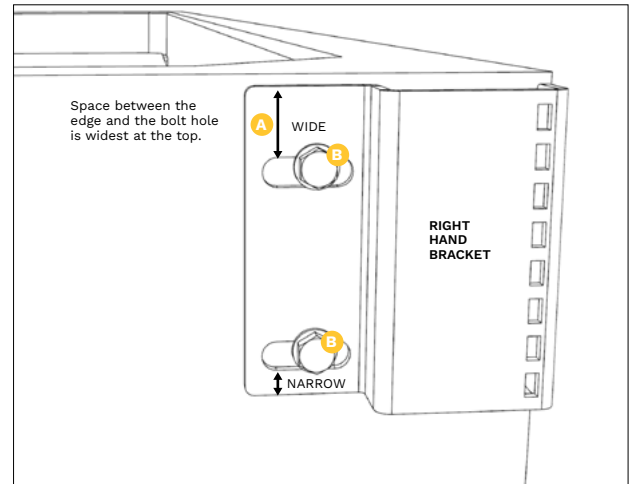

5. Screw the 12M all-thread into the Plungie wall using the existing mounting holes. **E**
6. Attach the coupler bolt onto the 12M all-thread. **F**
7. Hang the Sunbather Downunder unit using installed mounting bracket. **G**
8. Join the coupler bolt to the centre plate and tighten for added rigidity. **F**

**NOTE**  
 On hanging the downunder there should be a 5-8mm space between the two centre threads to allow for adjustment. **H**



A Fluidra Brand

**1800 228 437**

Head Office: 2174 Frankston-Flinders Road, Hastings 3915 VIC  
 QLD Office: 25 Industrial Crescent, Willawong 4110 QLD  
 NSW Office: Unit 5, 6 Gladstone Road, Castle Hill 2154 NSW

[sunbather.com.au](http://sunbather.com.au) • [info@sunbather.com.au](mailto:info@sunbather.com.au)

# Downunder In-Ground

## INSTALLATION WITH MOUNTING BRACKET

### Backfilling a mounting bracket

- Adjust the height of the downunder on the bracket so the top of the lid/end plate is level with the top of the pool pavers (finishing layer). **A**
- Replace protective cover to ensure no damage to the lid.
- Backfill around the unit approximately half the height of the unit. Do not cut any internal braces or protective coverings before installation. **B**

### Concreting and Paving/surface layer

- Ensure concrete ties are set to be fully encased in concrete, ideally linked to reinforcing bars for stability. **C**
- Cover the backfill with concrete allowing space for the paving(finishing layer). Finish paving ensuring its finished height is level with the end plate (datum line).
- Keep the protective cover on until all paving work is finished and cured. Only then, remove the cover.
- The builder must take care to avoid damaging the hinged lid during the installation process as concrete will burn anodising.

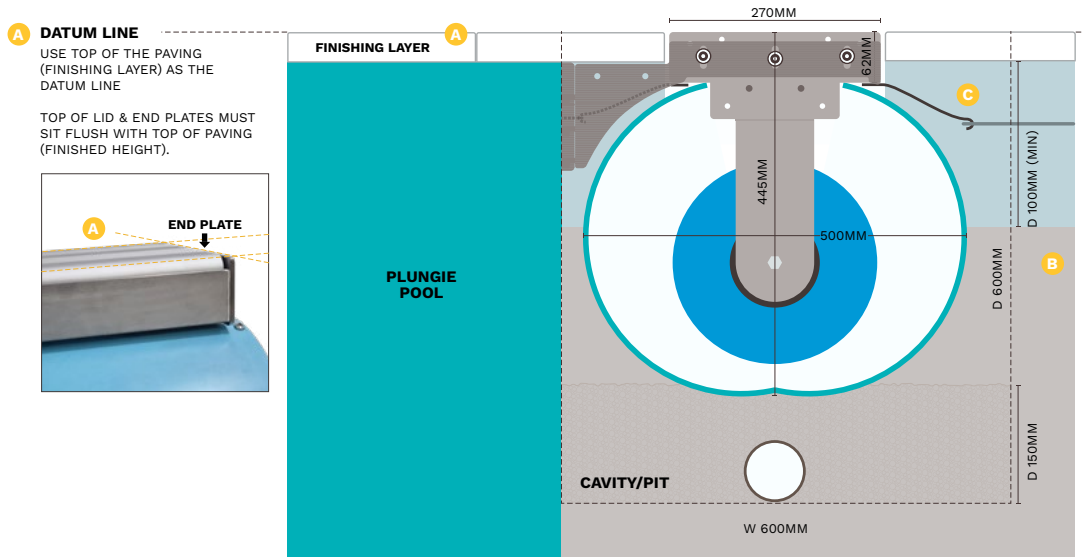

#### IMPORTANT

The Installation bracket is for installation assistance only and must be backfilled within 48 hours of installation.

MADE IN  
**AUSTRALIA**



[sunbather.com.au](http://sunbather.com.au)



A Fluidra Brand

**Call Sunbather's highly experienced team today.**

Find out how we can help you with all your solar pool heating needs.

**1800 228 437**



SOLAR HEATING



HEAT PUMPS



GAS HEATING



COVERS



ROLLERS

**HEAD OFFICE**

2174 Frankston-Flinders Rd,  
Hastings Victoria 3915

T: 03 5979 5777  
E: [info@sunbather.com.au](mailto:info@sunbather.com.au)

**SA**

PO Box 2078  
Morphettville SA 5048

M: 0419 033 930  
E: [sa@sunbather.com.au](mailto:sa@sunbather.com.au)

**QLD**

25 Industrial Crescent,  
Willawong, QLD 4110

T: 07 3806 5909  
E: [info@sunbather.com.au](mailto:info@sunbather.com.au)

**WA**

Midvale, WA, 6056

T: 1300 669 047  
E: [wa@sunbather.com.au](mailto:wa@sunbather.com.au)

**NSW**

Unit 5, 6 Gladstone Road  
Castle Hill, NSW 2154

T: 02 9894 7550  
E: [info@sunbather.com.au](mailto:info@sunbather.com.au)

**NZ**

Unit 1, 18 Corinthian Drive,  
Auckland New Zealand 0632

M: +64 21 0233 2600  
E: [justin@sunbather.co.nz](mailto:justin@sunbather.co.nz)