

INSTALLATION GUIDE

Lifting Guide

Original

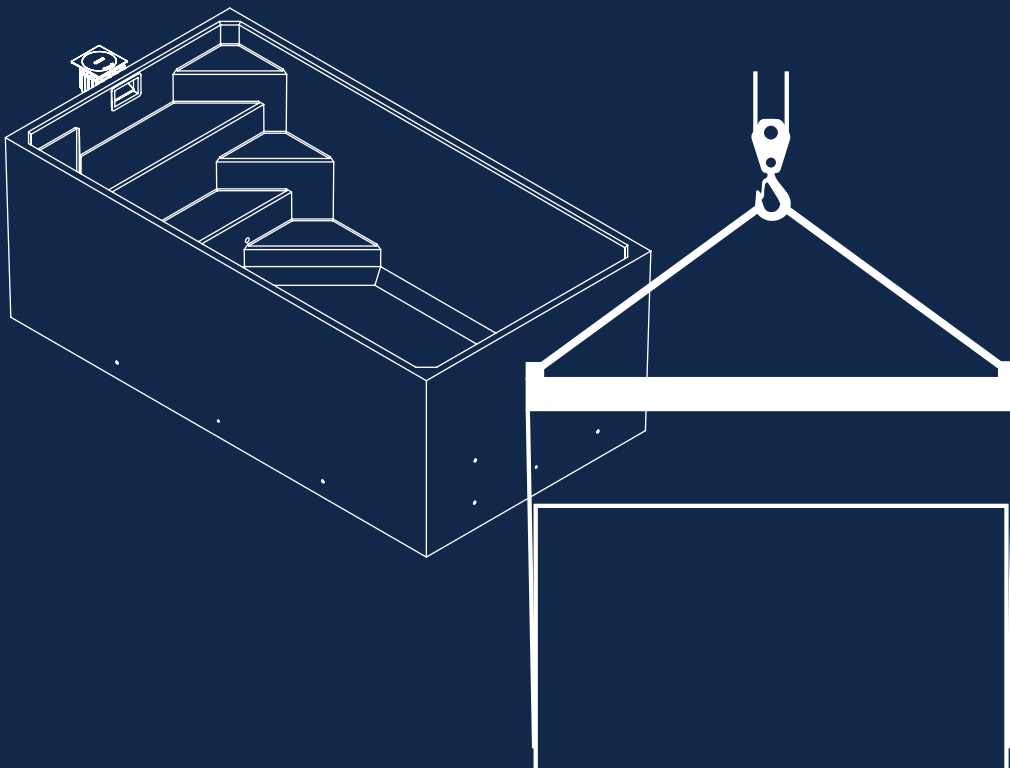

Lifting Diagram Original

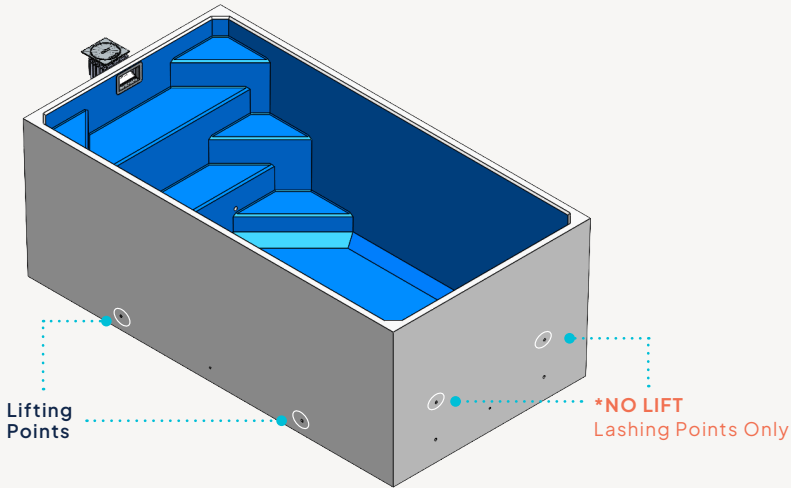

Plungie Original Lifting Specifications

Length	15 ft
Width	8 ft
Height	5.5 ft
Weight	17,500 lbs
Lift Type	Spreader bar with straps / chains
Lifting Points	1" x 4" Coil Bolts (provided)
Tool Required	1 1/2" Deep Socket and Extended Socket Ratchet

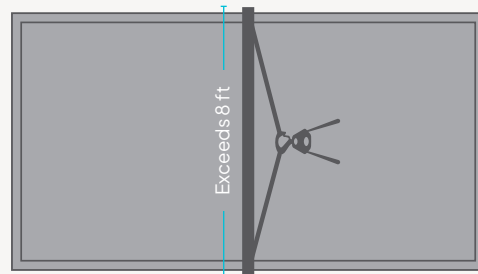
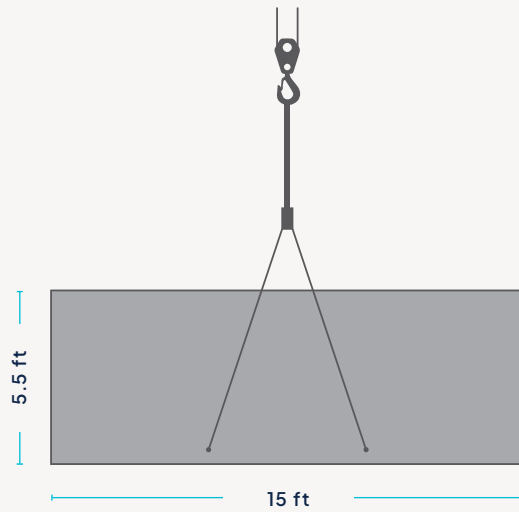

Please note:

The tools required must be provided by the crane company. Upon arrival, move the swivels from the lashing position to the lifting position. Damage to the product may occur if not lifted correctly. Padding or a guard may be needed in cases to prevent physical damage.