

PLUNGIE SPECIFICATIONS

# Plungie Studio

Specifications + Dimensions

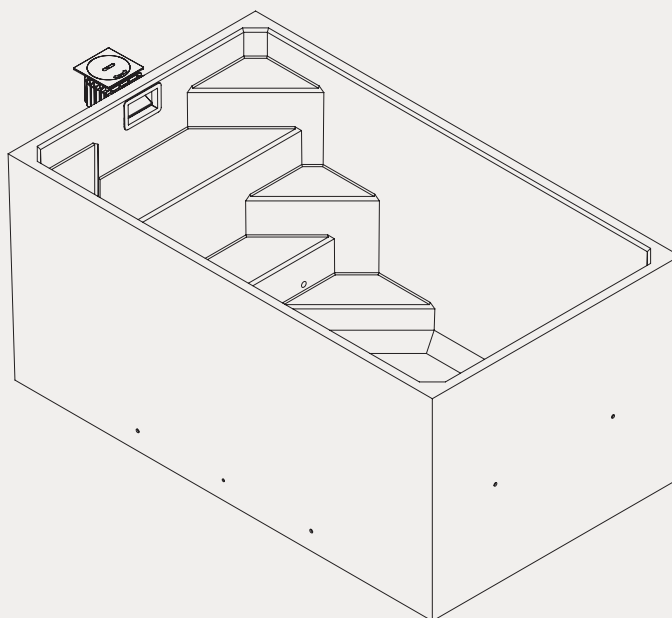

## Plungie Model

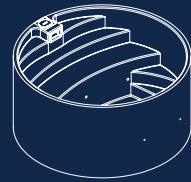

Plungie **Arena**  
11' 5" diameter

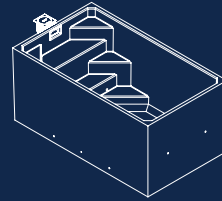

Plungie **Studio**  
12' x 7'

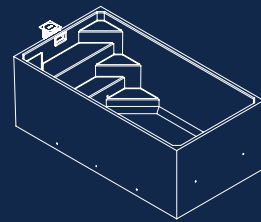

Plungie **Original**  
15' x 8'

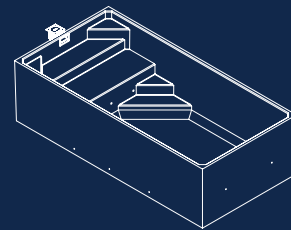

Plungie **Max**  
20' x 10'

Whilst Plungie Pty Ltd has made every effort to ensure the accuracy and effectiveness of this information, we make no representation as to the accuracy or effectiveness of the information and take no responsibility for any loss, damage or injury which may be caused as a direct or indirect result of the use of this information.

# Plungie Studio

12' x 7'

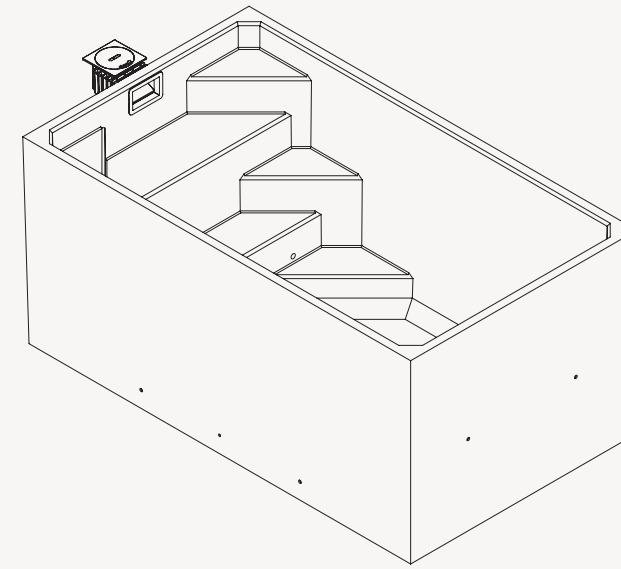

The sophisticated and sleek design of the Plungie Studio leaves nothing to wish for!

We've designed the Plungie Studio with smaller spaces in mind, making it an excellent choice for front yards and inner-city living. With over plenty of bench space to lounge on, the Plungie Studio will become your new favourite spot to enjoy a sunny day!



View the  
Studio online

## INCLUSIONS

- Highly engineered concrete pool shell
- High-performance ecoFinish interior coating
- Primary pool fittings pre-plumbed to shell including:
  - Multi-coloured LED Light
  - Skimmer Box
  - 2x pre-plumbed returns and 2x secondary suctions
- Hydrostatic valve
- Technical designs and pre-engineered specifications
- Our Plungie ten-year structural warranty
- Option to add equipment package including pump, chlorinator and filter

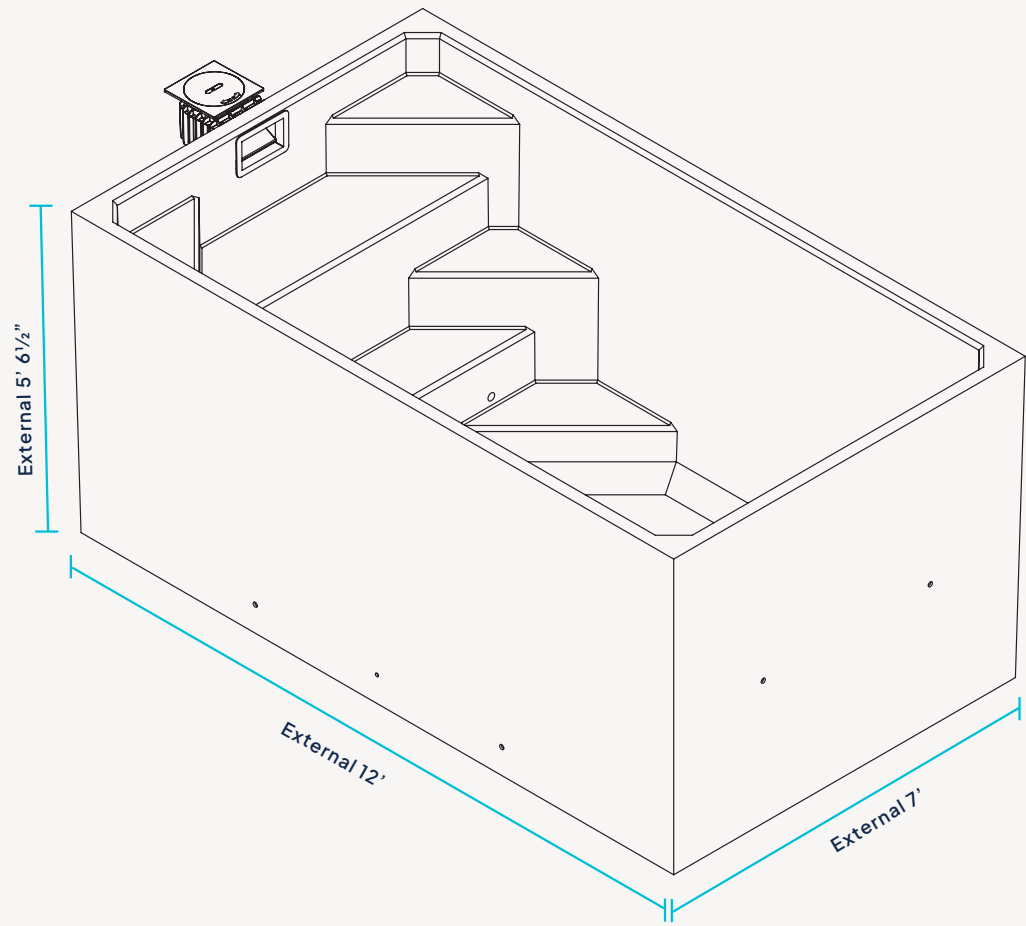

Length	External 12'
Width	External 7'
Height	External 5' 6 1/2"    Internal 5' 3"
Volume	2,100 gal
Dry Weight	13,200 lbs

## AERIAL DIMENSIONS

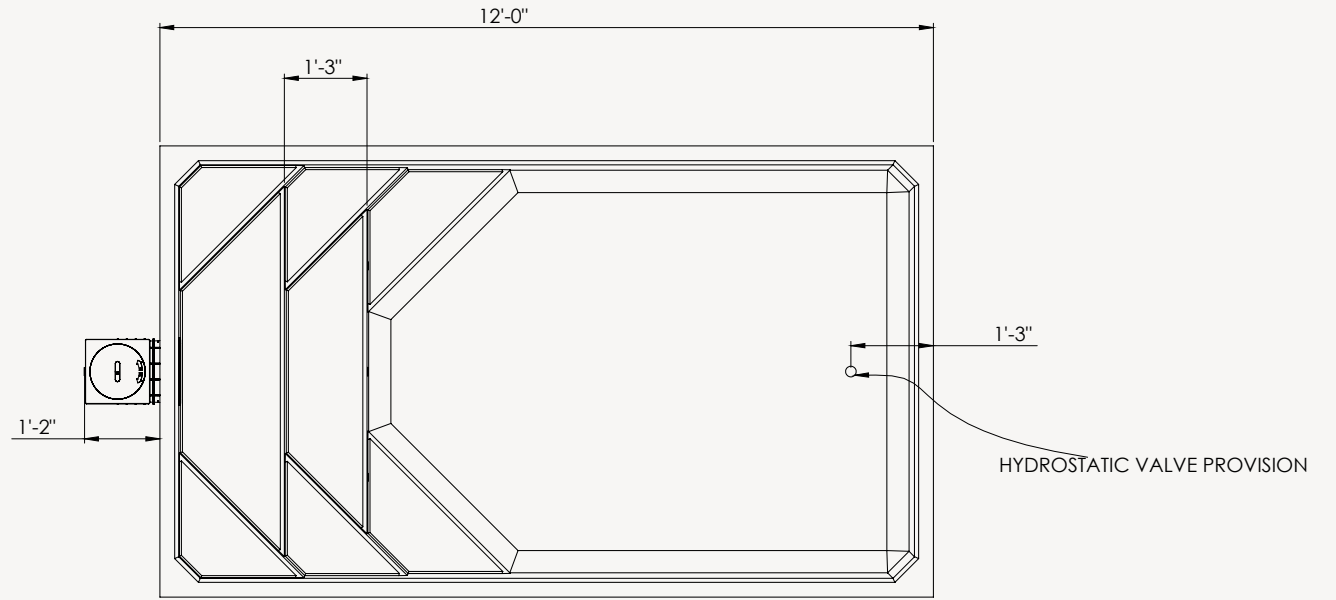

## SIDE VIEW

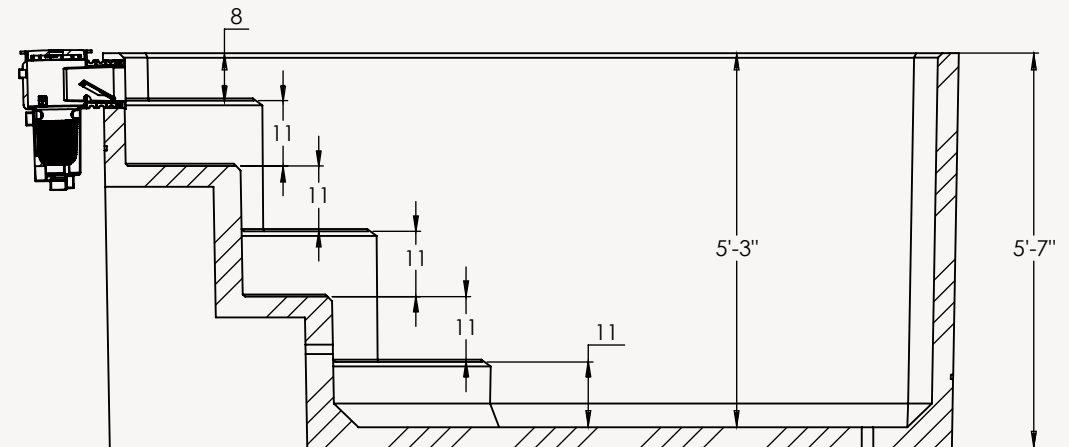

## SKIMMER / STEP END VIEW

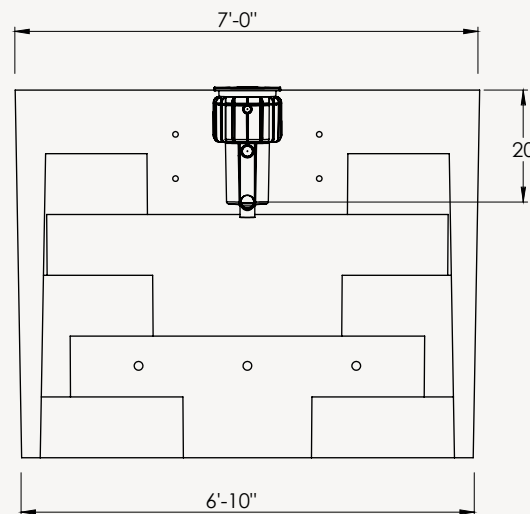

## SKIMMER BOX

